

EXPERIENCE MOBILITY

ELROFORM™ PRODUCT SOLUTIONS.

INNOVATIVE SOLUTIONS FOR xEV APPLICATIONS.

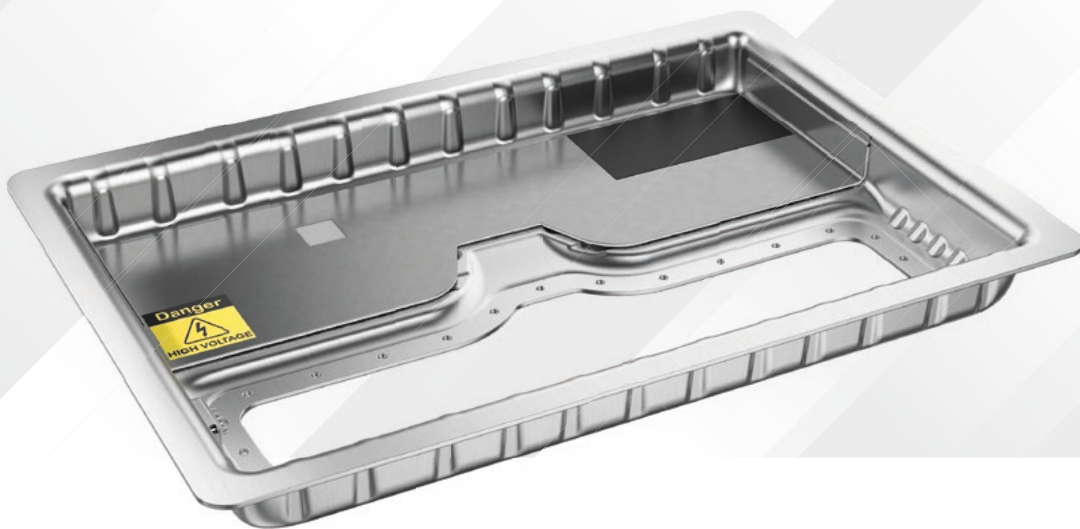

SYSTEM PARTNER. PROBLEM SOLVER. PIONEER.

SHAPING THE FUTURE. WITH ELRINGKLINGER.

For us, system expertise means being a pioneer, creating freedom and reaching goals faster. With our portfolio, we offer groundbreaking solutions for all vehicles, whether traditional, hybrid or pure electric.

Proximity to the customer, developing visions, overcoming challenges and driving forward innovations: Those are our key strengths, that's what has made us what we are today.

YEARS LEADING THE WAY



140

Nothing can replace experience combined with innovative spirit. ElringKlinger has plenty of both. In 1879, Paul Lechler founded a trading company for technical products, which would later become ElringKlinger AG. Today, we are a global player offering future-proof solutions for all drive types in all product areas. We also demonstrate our strengths in other industrial sectors. Our customers benefit from ElringKlinger's combined materials, design, development and manufacturing expertise. Thinking ahead, developing solutions, being the first to break new ground, taking responsibility. That's what sets us apart – for more than 140 years.

4

STRATEGIC
KEY AREAS

Alternative drive technologies, lightweight engineering concepts, new forms of mobility, sustainability and climate protection: The transformation process in the automotive industry is in full swing. The agenda for the future is clear. We are also working every day to play our part and push the limits of what is possible. We are focusing on four strategic fields: Electromobility, lightweight construction for all drive types, traditional mobility and non-automotive. Together with our customers, we are already finding answers to the questions of the future. And successfully driving forward innovations.

10,000

EMPLOYEES AS PARTNERS

For our customers, we are a strong and reliable development partner and series supplier with unique expertise. We are a pioneer and companion. From the idea to the finished product. Whether electromobility, lightweight engineering, gasket and shielding technology, tool technology or engineering services – ElringKlinger impresses with the highest quality, reliability and performance. Around 10,000 employees are committed to achieving this at 45 sites worldwide.

EXPERTISE FOR THE TRANSFORMATION

INNOVATIVE IDEAS ENHANCE PROVEN SOLUTIONS.

For decades, ElringKlinger has been developing and producing multi-layered sheet metal parts – better known as ElroShield™ M. With its latest innovation ElroForm™, ElringKlinger’s product range now includes molded metal parts and assemblies for xEV applications. ElroShield™ EV combines the very best of ElroShield™ M and ElroForm™ and is targeted at the mechanical, thermal, acoustic, and electromagnetic function of xEV applications.

SPECIAL DIMPLED STRUCTURE ENSURES ADDED VALUE

As a single-layer design, the used raw materials are usually embossed before being formed in the tooling. This firstly increases the component’s stiffness, enabling weight reduction via using thinner materials, and secondly, it reduces the tendency for structure-borne noise. Further possible variants include flanging as a safety edge, perforation of the material, and the assembly of additional add-on components.



ELROSHIELD™ S

ADVANTAGES:

- + Special dimpled structure of the raw material minimizes the tendency for structure-borne noise and increases component stiffness, i.e. weight reduction is possible because less material is used
- + With safety edge
- + Low production costs

APPLICATION AREAS:

Used primarily in areas with lower thermal requirements, e.g., in the underbody area.

GOOD SERVICE NOT ONLY ALONG THE UNDERBODY

ElroShield™ S is typically used in the underbody area, partly in underhood applications, but also for electromagnetic shielding.

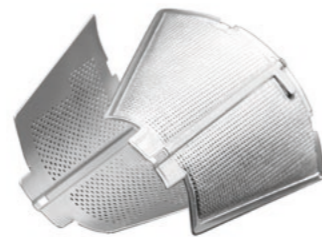

MATERIAL STRUCTURE:

ElroShield™ S
Single layer

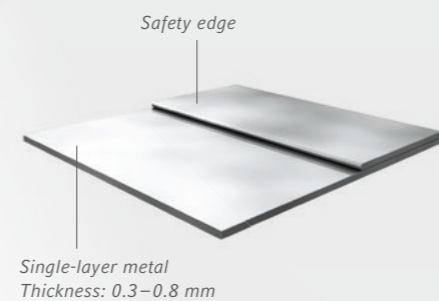

ELROSHIELD™ EV

For plug-in hybrid, electric battery or fuel cell vehicles requiring thermal, acoustic, and/or electromagnetic properties.

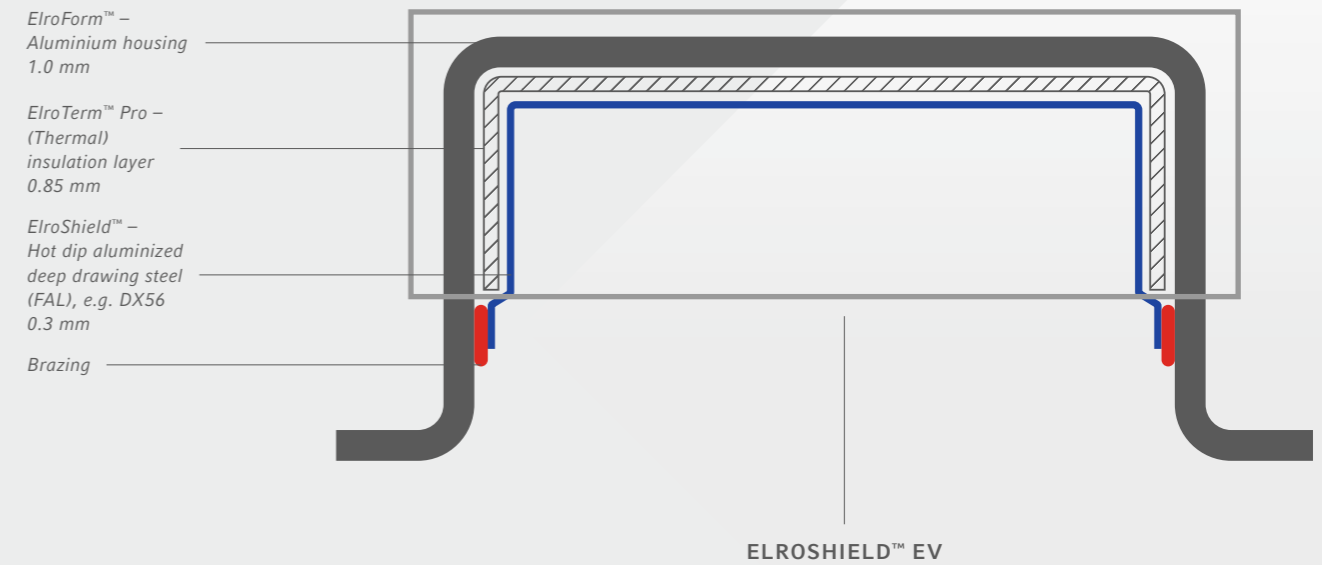

KEY PRODUCT BENEFITS

- + Ensuring structural strength and rigidity with a high-strength outer shell
- + Potential weight savings of more than 50 % due to combination of a structural design and the use of thin sheets
- + No additional coating necessary
- + Excellent thermal properties in terms of “thermal propagation”
- + Improved electromagnetic properties
- + Improved acoustic properties (if necessary)
- + Large-scale solution at low costs to promote sustainability

THE PERFECT SOLUTION FOR ALL INSTALLATION POSITIONS

OUR SOLUTIONS FOR xEV APPLICATIONS.

The ElroForm™ type shielding systems are primarily used at various positions in partially or fully electrified drive concepts.

LIGHT WEIGHT SOLUTIONS IN SHEET METAL DESIGN

On-board charger cover



Inverter cover



High voltage cover



Brake disc shield



Cover for Electric Drive Units (EDU)



MEASURES FOR FIRE AND HEAT PROTECTION

Battery case



Battery cover



Venting cover



Battery insulation

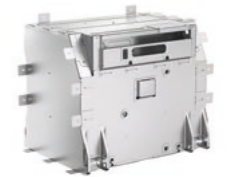

Oil shield gearbox



Modul Housing



Intermediate plate



Module cover

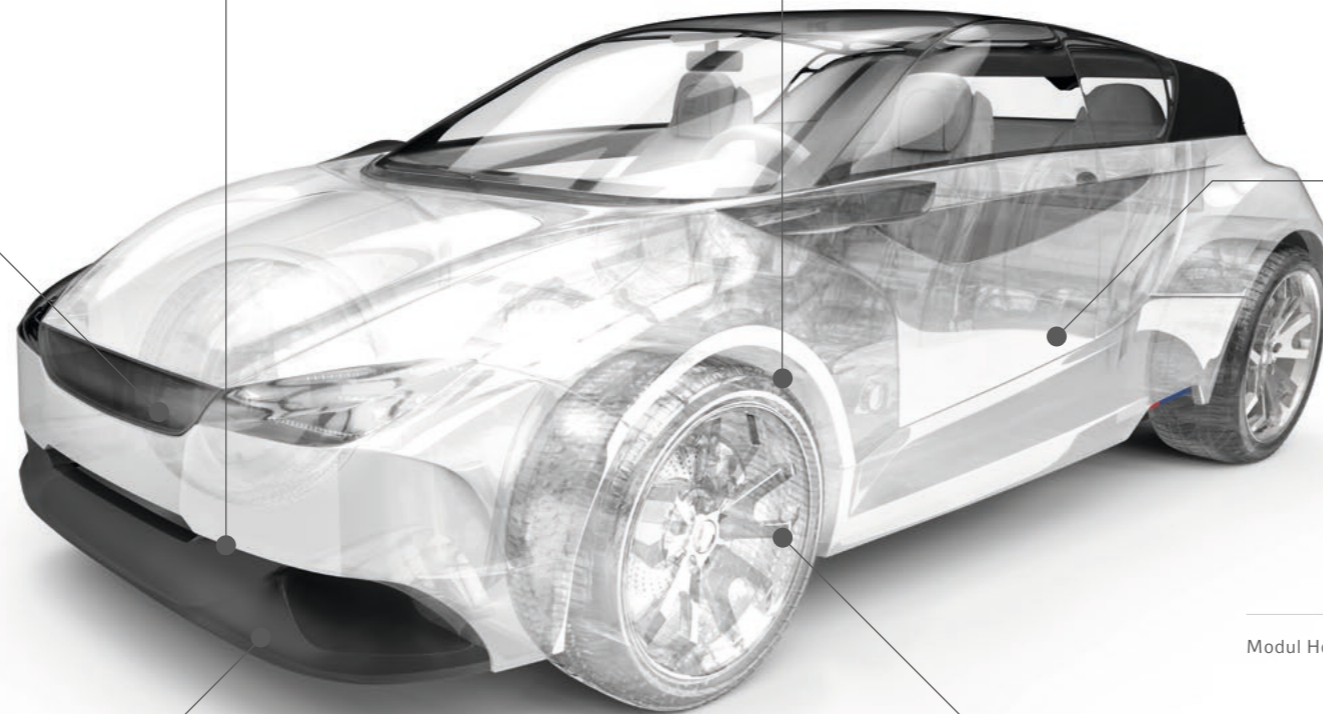

INNOVATIVE COMPONENTS GUARANTEE MAXIMUM COMFORT

ELROFORM™ PRODUCT SOLUTIONS KEEP OUT HEAT AND BLOCK SOUND.

In vehicles with electric drives, power and control electronic components cause perceptible noises in characteristic operating conditions. Thanks to targeted optimization of individual components, materials, and designs, our ElringKlinger team has succeeded in developing a significantly higher product quality. This ultimately means considerably greater comfort for customers.

SOUND DESIGN IMPROVES PRODUCT QUALITY

In electric vehicles, the NVH performance of components is more important than ever. While in vehicles powered by combustion engines the dominant noises were those emitted by the engine and exhaust system, in electric vehicles the noise emissions come mainly from converters, electric motors, power electronics, and tires. This makes it even more important to detect sources of sound, identify propagation paths, and define optimization measures. Based on the component FEM calculation (see also "Good to know"), the NVH performance can also be analyzed and potential improvements can be identified during development. This pays off down the line. The acoustically efficient materials and designs used in vehicles have a significant influence on the comfort of customers and their perception of product quality.

ACOUSTICALLY EFFICIENT COMPONENTS

If required, experts and ElringKlinger can analyze all the conditions that can occur on actual components and in their surroundings before prototype production. Resonant frequencies and their modes are simulated and the components undergo beading optimization based on the ERP method (determination of the maximum radiated acoustic power). Finally, after testing and optimization of further parameters using acoustic simulation, an acoustically efficient component tailored to customer requirements is produced as an additional function.

GOOD TO KNOW

The finite element method (FEM) simulates the subsequent use of the component on a computer and analyzes the points subject to exceptional stresses. Based on the results, the shaping, type of materials, surface topography, and attachment can be optimized and implemented in the CAD model.

INITIAL DESIGN

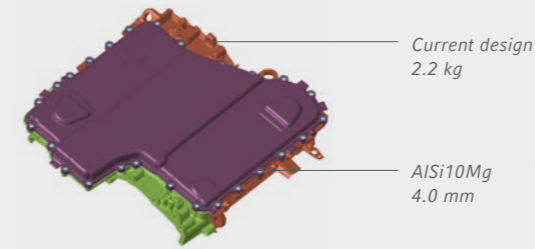

LIGHT WEIGHT DESIGN OPTIMIZATION

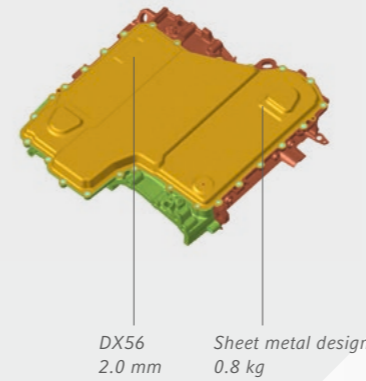

NVH OPTIMIZATION

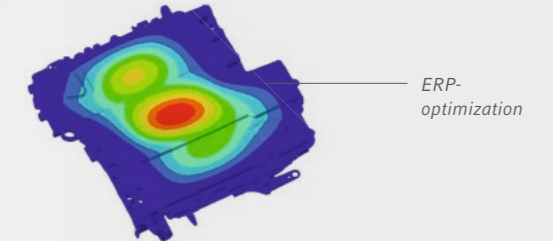

NVH OPTIMIZATION



OPTIMIZED ON-BOARD CHARGER COVER

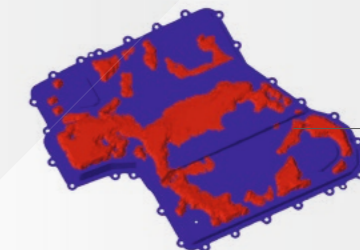
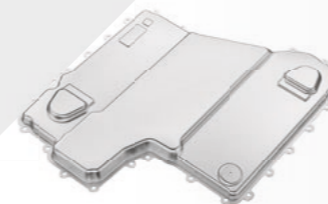

COMPONENT OPTIMIZATION EXAMPLE – ON-BOARD CHARGER COVER

The benefits of ElroForm™ can be highlighted using the example of an on-board charger cover. Thanks to smart material selection combined with know-how gained from the simulation method for acoustic optimization, considerable potential can be utilized. Converting an original cast component to a multi-layer version with an ElroForm™ design greatly reduces the mass. This is linked to cost savings, without impairing the main function of acoustic efficiency. On the contrary. The ElroForm™ design actually reduces acoustic emissions from their previous level.

KEY BENEFITS

- + Weight saving 64 %
- + Cost saving 30 %
- + Frequency optimization + 50 %

EXPERT PARTNERS

RELIABLE PARTNERSHIP FROM A TO Z.

For ElringKlinger, supply expertise means reliability from a single source. From the development, production, and preassembly of add-on components up to automated function checks and quality control are carried out. Including “just-in-sequence” delivery of ready-to-install shielding systems to the assembly line.

STATE-OF-THE-ART PRODUCTION PROCESSES

Our ElroForm™ assemblies are produced in modern factories with state-of-the-art assembly lines – fast, cost effective and in high quality. Fully automated press lines and robot-aided processes allow high efficient production of both high volumes and small series. Online quality inspection is performed using camera systems during the production process itself.

DIRECT COORDINATION

Production is carried out around the world at numerous plants that are certified to ISO/TS 16949, ISO 14001 and ISO 9001. We can meet customers wishes directly on production site. The advantages: clear responsibilities, speed, flexibility, maximum quality, and full service. Worldwide.



OUR PORTFOLIO. FOR YOUR SUCCESS:

- + Battery technology
- + Fuel cell technology
- + Electric drive units
- + E-mobility components
- + Lightweight and elastomer technology
- + Sealing systems
- + Shielding systems
- + Components from high-performance plastics
- + Dynamic precision parts
- + Tooling technology
- + Engine development services
- + Aftermarket

ElringKlinger AG

Max-Eyth-Straße 2
72581 Dettingen/Erms
Germany
Phone +49 7123 724-0
E-mail info@elringklinger.com

www.elringklinger.com

The data provided here are the result of technological investigations. Such details are subject to change depending on the design of the system. We reserve the right to implement technical changes and improvements. The data are nonbinding and do not represent guaranteed characteristics. We accept no claims for compensation based on this information. We accept no liability for printing errors.