

PEMFC stack module NM12 Single

GENERAL FUNCTION

EKPO develops and produces PEMFC stack modules that are based on patented designs for metallic bipolar plates as well as end plates and media supply assemblies, providing many benefits for integration into fuel cell systems. Low-temperature fuel cell stacks from EKPO have excellent power and durability characteristics and can be used for a very wide variety of vehicle categories. Due to a chemical reaction between oxygen and hydrogen, electrical energy is generated which, depending on system design, can directly supply an electric motor or charge battery modules in the vehicle. Power class NM12 Single is available with a stack configuration of 359 cells. At 2.5 bar_a operating pressure it achieves a power output of up to 123 kW_{el}.

The PEMFC stack module NM12 Single is designed for applications with high power requirements (>100 kW) in the automotive and rail sectors.

TECHNOLOGY

Our established processes and experience in production technology have given us decisive advantages for series development and production in the field of fuel cells.

- / Automated, high-precision and interlinked production of metallic bipolar plates
- / Series-compatible development and manufacture of end plates and media modules made of plastic
- / Flexible and automated stacking operations as well as assembly of the stacks

PARAMETERS

- / Customer-specific stack solutions with power levels up to 123 kW_{el}
- / Hydrogen-air operation
- / Liquid-cooled
- / Pressurized operation up to 2.5 bar_a
- / IP [6KX, X6K, X7] housing with EMC shielding
- / Compact integrated cell voltage monitoring [CVM]
- / Integrated media control, water separators and media monitoring
- / Robust sensors and actuators acc. to automotive standards
- / Stack module validated acc. to IEC 62282 and GB/T 33978



 **BENEFITS**

- / High power density due to lightweight, compact stack design
- / High dynamic response in power provisioning
- / Robust component and stack design suitable for mass production, with long service life and minimal power degradation
- / Proven cold-start performance and durability
- / System simplification by integration of functions at the media supply assembly of the stack (sensors, actuators and valves)
- / Metallic bipolar plates in patented designs

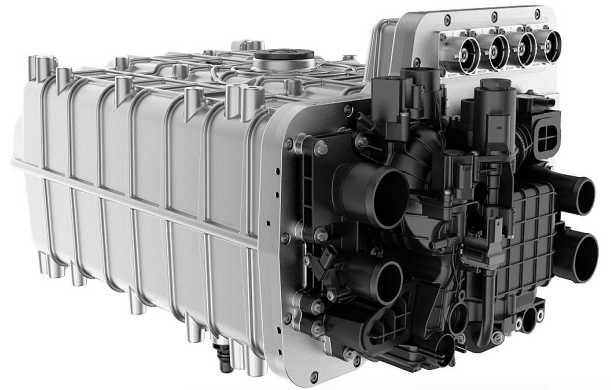

 **SPECIFICATIONS**

GENERAL DATA

Cell Count	359
Rated stack power	123 kW
Power density stack ¹	4.2 kW/l
Power density cell block ²	6.2 kW/l
Rated stack voltage	215 V
Rated current ³	570 A [2.28 A/cm ²]
Max current	625 A [2.50 A/cm ²]
Rated operation pressure	2.5 bar _a
Active area	250 cm ²
Cell pitch	1.27 mm
Orientation	cells vertical
Dimension incl. housing	448x349x739 mm

¹ value refers to cell row assembly including compression hardware

² based on bipolar plate contour

³ current at 0.6 V cell voltage

 **EKPO – YOUR INDUSTRIAL FUEL CELL PARTNER**

Component and Stacks, from development to series production

 **YOUR CONTACT**

EKPO Fuel Cell Technologies GmbH

Phone +49 7123 724 - 200

E-mail info@ekpo-fuelcell.com